

# **OWNER MANUAL**

# Contents

Preface	1
Vehicle safety driving	2
Parts description	3-5
Odometer	6
Left switch	7
Right handle switch	8
Additional function and gear oil maintainance	9-10
Brake system	11
Wheels	12
Battery	13
Important notice	14-15
Regular default and maintainer instruction	16-18
Technician Specification	19
Wire diagram	20

# Preface

This manual introduce the basic E-bike operation and maintenance methods, please read them carefully before riding. Please ride, maintain properly so that you can avoid the fault and keep the good function, prolong the lifetime. Our after service shop locally , could sincerely provide the best service for you.

The owner manual show the updated data, instruction, specification and pictures according to actual products. Our company persists the right of change , sorry for not the additional notice to you for the change.

Thanks for choosing E Bike. Please enjoy her comfort and pleasure in the future journey. Please enclose herewith the owner manual when you transfer the possession of this product.

his owner manual cover the following model:

- KL800DZY(K3)

Since this manual covers a few model and specification, the pictures listed are not covering all of the parts or spec, so please take the actual products as the standard.

Please read this manual carefully. Please do not ride it before unknowing its characteristics.

---

## Safety riding

### Attention

1. please obey the local traffic safety , check the vehicle carefully before riding .
2. please do not ride the bike on high way

### Rule for safety ride

Please check the tire pressure

Please check the brake function daily.

Please adjust the seat position properly in order for you to ride your bike comfortably..

Please adjust the back mirror in order for a better view

Please start it by key, check the battery electricity capacity. Please switch to the correct forward or backward position, accelerate the right handle steadily. Please pay attention to the speed to avoid unnecessary accident.

Please slow down the bike when steering.

Please brake by stopping the bike, power off the bike every time you stop, then pull the hand brake

Emergency situations: If electric can not cut off with electrical faults occur or other reason, press the controller switch off urgently

### Customarize:

Any modification or change on the original configuration can not make sure safety driving,also it is illegal, Users must obey the regulation by transportation department

## Parts Position

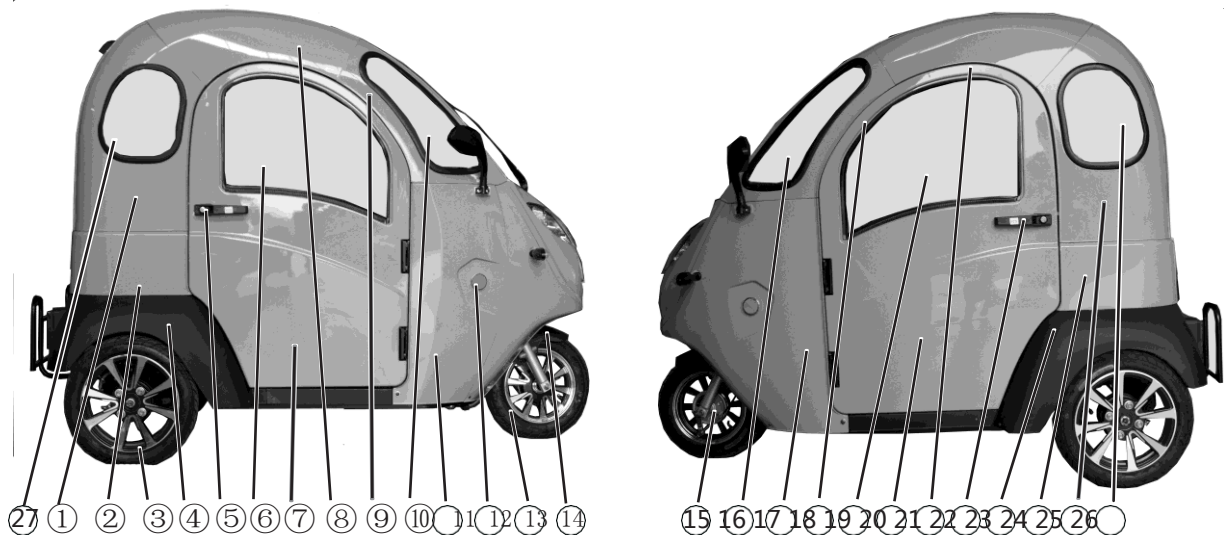

- ①Rear shed .R②Rear fence .R③Rear wheel④Wheel cover .R⑤Door Lock .R⑥Door glass .R  
 ⑦Door set .R⑧Ceiling .R⑨Front window .R⑩Front glass .R⑪ Side cover .R⑫ Reflector  
 ⑬ Front rim⑭Front fender⑮Front drum brake ⑯Front glass.L⑰Side cover.L⑱Front window.L  
 ⑲Door glass .L⑳Door set .L㉑Ceiling .R㉒Door lock .L㉓Wheel cover .L㉔Rear fence .L  
 ㉕Rear ceiling .L㉖Rear window glass .L㉗Rear window glass .R

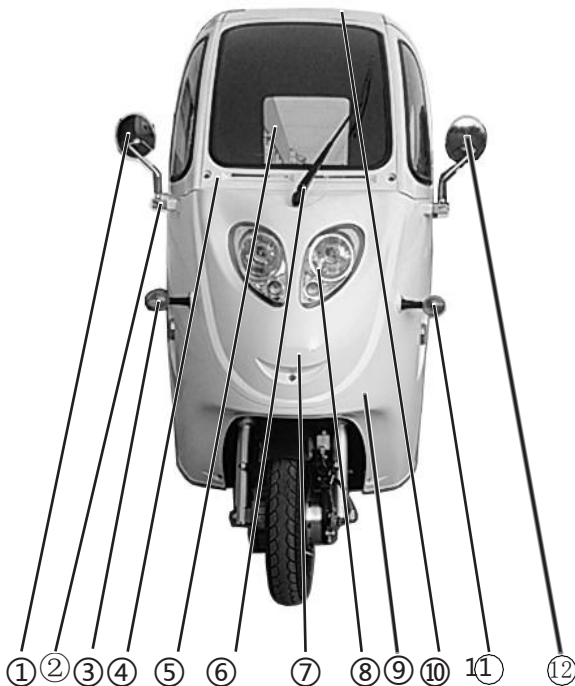

- ①Rear view mirror .R ②Rear view mirror holder③Turn light .R④Front middle window  
 ⑤Wind shield⑥Wiper motor⑦Front headlight cover⑧Headlight⑨Front fence⑩Middle ceiling  
 ⑪Turn light .L⑫Rear view mirror .L⑬tail light .L⑭Wheel cover connector⑮Rear middle fence  
 ⑯Rear middle ceiling⑰Rear wind shield⑱Tail light .R



① ② ③ ④



⑤ ⑦ ⑧

①Rear cushion②Rear fence frame③Rear fence cover④Ceiling⑤Right carriage  
⑥Left carriage⑦Tail frame⑧Ceiling frame

## Chassis Label

Visible from position①in the picture

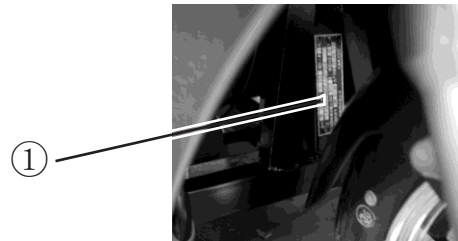

## Speedometer

①Speedometer  
KM/H

②Turn light .L

Glint when switch on

③Voltmeter

Voltage display

④ Power meter

Power display

⑤Turn light. R

Glint when switchon

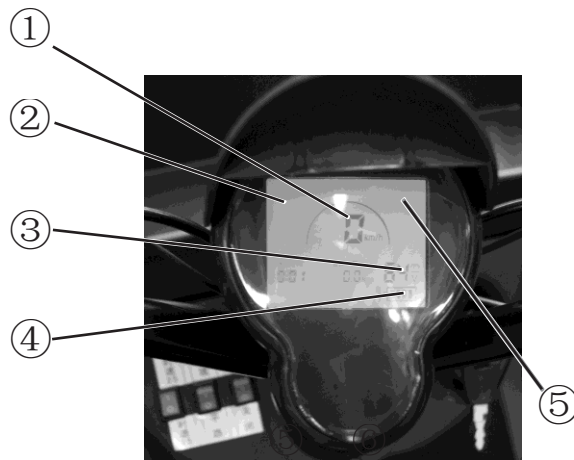



## Ignition switch

Position①: Circuit switched at this position , bike can be start ,forward and reverse ,key cannot be pulled out

Position②: Circuit disconnect

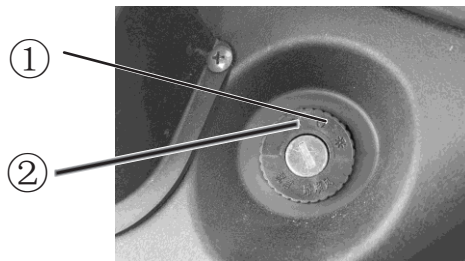

## Left switch assy

### ①Headlight switch

At position “●” headlight switch off, when power on, at position “○” headlight switch on.

### ②Horn

Horn works while press and off while release.

### ③Turn lights switch

Switch at position “●” All turn lights are power off, when switch at position “⇐” Left front and rear turn lights both switch on with glint, when switch at position “⇒” right

front and rear turn lights both switch on with glint

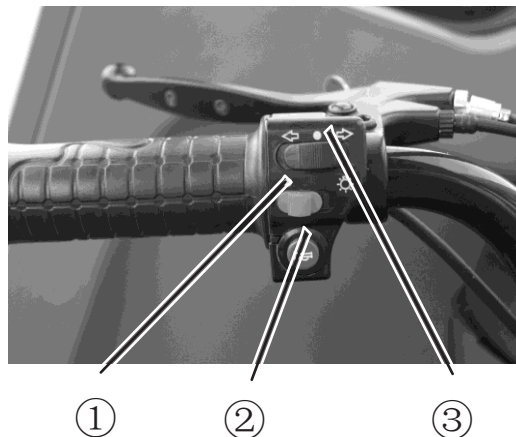

## Function Switch

Mark①is speed limit switch ,with 25KM/H when switch on and 15KM/H when switch off,  
Mark② is power switch ,climb driving when switch on and normal road driving when switch off,  
Mark③ is EBA switch , enhanced brake function and auxiliary brake when switch on

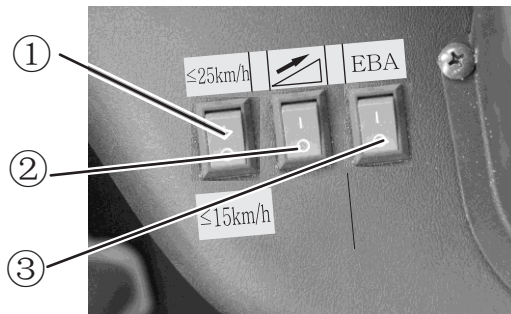



## Right handle acceleration switch

### ①Forward and reverse switch

At forward gear, bike forward ,at reverse gear bike reverse

### ②Wiper switch

Press to position “” motor start wiper ,press to position “” motor stop wiper.

### ③Acceleration grip

Acceleration lever are use for speed adjust, grip toward to driver is speed up,conversely is deceleration

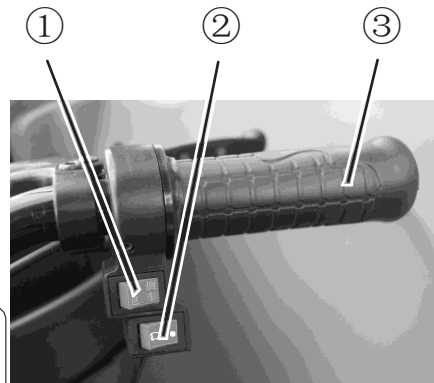

### Caution

Before start the bike, check movement of grip is free or not , grip must be free move without any obstruction

## Power switch

Power switch located in the front of main seat, switch at position “on” ,bike can start with ignition on ,when at position “off” ,bike power off, can not start



## Window glass lifter

When whirl the arm of lifter with clockwise direction, glass down , with counterclockwise direction, glass up.

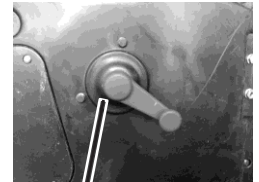

Arm

## Seat movement

### Seat forward and reverse movement

Move up the handle in picture① ,the move the seat like picture②to suitable position, handle can self lock when you put down ,if cannot ,adjust a little bit until self lock.

**Caution**  
Seat adjustment must in a quiescent status,  
make sure the seat are locked before bike start

## Door lock

Open the door set with key follow picture ③,press lock in front ,pull the handle on the door ,door can be open.

## Motor gear oil

When oil change, put an empty box under the motor ,take off the inlet and outlet oil bolts ,release oil ,screw the oil release bolt ,add new oil in the inlet hole, screw the oil inlet bolt when finalize oil change .

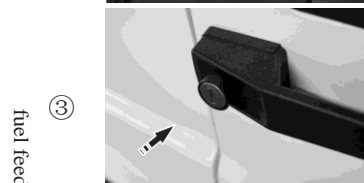

fuel feed holebolt

drain oil hole bolt

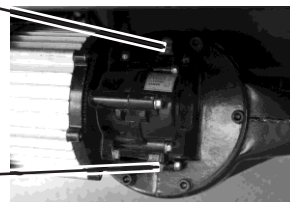

## Brake system drum brake

Drum brake will wear and tear after use for some time , in order to ensure brake and reliability of the brake system change the drum when wear and tear to limited thickness.

### Caution

With new drum change, please do not drive immediately control the lever several times for brake system return to normal status

## Brake adjustment

Adjust the nut by clockwise direction can reduce the free route of the brake ,by counterclockwise direction can increase the free route of the brake

### Caution

After brake adjustment need brake several times before release, whirling the rim,check the rim can free move or not

## Brake system

Inspection items before driving everyday

- A.Adjust nut loosen or not
- B.Rear throttle cable wear and tear or not
- C.Rear drum brake work or not



front drum brake

adjust nut

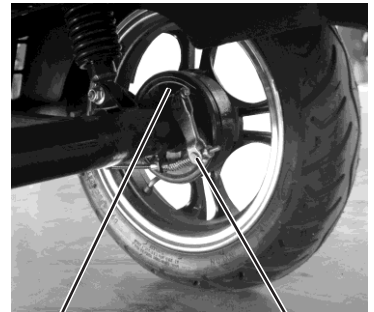

rear drum brake

adjust nut

## Wheel

### Caution

Extremely dangerous to use excessive wear tires, affect the stability of steering and steering traction, wrong tire pressure will cause tread wear and accident

Note: Check tire before driving, if any problem, need change a new one

Mim tread depth (mm)	
Front:1.5	Rear:2.0

Correct tire pressure will keep the stability of tires as well as long time use

Load	Tire pressure (Kpa)	Tire pressure (Kpa)
Driver	Front:250	Rear:250

## Battery

### Charger

1. Plug the charger to the triplex and connect to the power.
2. Red means the battery is under charging, last 10-12 hrs
3. The light turned from red to green means finish.

### Attention

Confirm the voltage before charging.

When charge the triplex , just connect the charge to plug and power, will take 10–12 hrs to have full charge, if long time the bike not start,make sure the battery is full charged, monthly otherwise will damage the battery, pull the hand brake and switch off the triplex when charging.

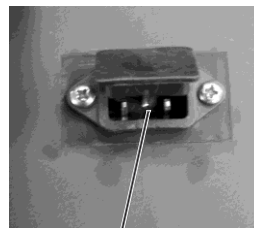

charger jack

Charger must be in the place with good air flow and without fire&something easy get burned.if the charging connect joint(metal one) damage ,please repair or change

Charger is specialize , make sure charger specs are same with voltage and Ah.

Do not open the charger .

## Maintain on battery

Battery no use is power loss 。 Power loss status is no charging on time 。 It will be vitriolization in storage life, battery capacity descend. heavier damage on battery if longer storage time so, charge battery every month basically; charge it after riding 。

If the continuation of the journey suddenly descend over 10km, at least one battery might be problem 。 so please check with the local dealer to check it, repair or use new battery set. this way can extend the lifetime of battery, save your cost.

The bike is big electro-discharge when starting, loading passenger,climbing, please be avoid accelerating, big discharge leads to sulphuric acid crystallize, and damage its physical function of the battery plate.

you should know its charging rate by normal usage 。 If the coulomb meter indicator shows50-60% ,you can charge it; if left20-30% , you should stop riding and charge it otherwise over discharging will shorten its lifetime.if over charging,the battery will over heat and loss of water normally the battery charging time is 10 hours. if the battery temperature is over65°C , please stop charging, and check if it is full.

Please don't let your bike under the blazing sun. inside pressure of battery will lose the function and speed its aging.

If power plug loose,oxidize leads plug over heat, long time leads to short circuit or bad connect damage its charger and battery, make you unnecessary loss. you need to clean



oxidize or replace connector clip.

Please check battery electrolyte liquid level, normally you need to add distilled water after riding 3–6months.

## Maintainance check list

Please check your bike per following instruction. The signal stands for the belows:

1、 check, clean, adjust, lubricate or replace C: clean R: replace A: adjust L: lubricate

I: check

\* need to check by engineer or you can maintain it by special tool,parts

\*\* These items need to be maintained by special mechanic.

Items \ Times		Cycle	Speedok m (Note)				
			1000km	4000km	8000km	12000km	Note
**	Motor gear oil		Every 6 month				
**	Rear brake			I	I	I	
**	Brake pad worn			I	I	I	
**	Front brake		I	I	I	I	
*	Rear brake light	1 month	I	I	I	I	
*	Front&Rear light	1 month					
*	Nuts& Bolts	1 month	I	I	I	I	
**	Rim	3 months	I	I	I	I	
**	Steering	6 months	I	I	I	I	
**	Battery		250 times charging per year				

### Important note

- ① Check the battery and brake before driving, if any problem must be solved before use
- ② Charging parts or fuse repair or change must switch off the power and disconnect the charger

③Remember:Always driving on the bad roads or overload need check the bike every day on the support power point and welding,if any problem must repair on time

④Must switch off and take off the keys and pull the hand brake when parking

⑤Battery repair or change as well as electronic parts repair and change must switch off the bike and disconnect the power

⑥When kids in the bike, must switch off the bike and take away the keys

⑦Check the doors whether closed before driving 。

⑧Charging place must without kids or kids can touch 。

⑨If bike on fire because of accident or other reason must switch off the power。

⑩Switch off the key when parking in order to avoid accident。

⑪Bike must be handled on platform, the trail speed must lower than the bike itself when need , better take off the motor and controller the wires of the motor must insulation in order not damage the electronic parts

⑫Unless emergency ,do not switch on the alarm device; when emergency alarm switch on ,the turn lights will not work.

## Fault and Maintenance

Fault	Reason	Solution
Voltage gauge not working when power on	①Circuit disconnection ②Voltage gauge not work	①Find circuit place and connect ②Change voltage gauge
Bike cannot use when voltage gauge work	①Electrical circuit not work well ②Battery voltage too low ③Hand brake not full released ④Electronic parts damage	①Check wire connection where loosen them re-connect ②Check voltage of battery ③Full release hand brake ④Find problem parts:Motor (right grip)controller、right grip (need service ability)
Brake problem	①Two brake not synchronize ②Brake pad worn	①adjust brake②replace brake
motor no power	Lack of power	Need charge
Not full charge	①Charge plug ②Charger damage ③Battery problem	①Change ②Change ③ Exclude battery problem

### KL800DZY(K3) Main Specs

Parts	Items	Unit	Type or specs
Bike	Measure: L×W×H	mm	1900×1100×1550
	Wheelbase		1450
	Rear tread		800
	Weight	kg	160 (Without battery)
	Passengers	unit	2
	Max speed	km/h	≤12
	Front tire&pressure		3.00-10 250Kpa
	Rear tirepressure		80/90-12 250Kpa
	Distance	km	50
Electronic	Headlight		12V35W/35W
	Front(Rear) turn lights		12V10W
	Tail/brake lights		12V21/5W
	Battery		20Ah
	Battery QTY	pc	5/6
	Horn		12V 105dB

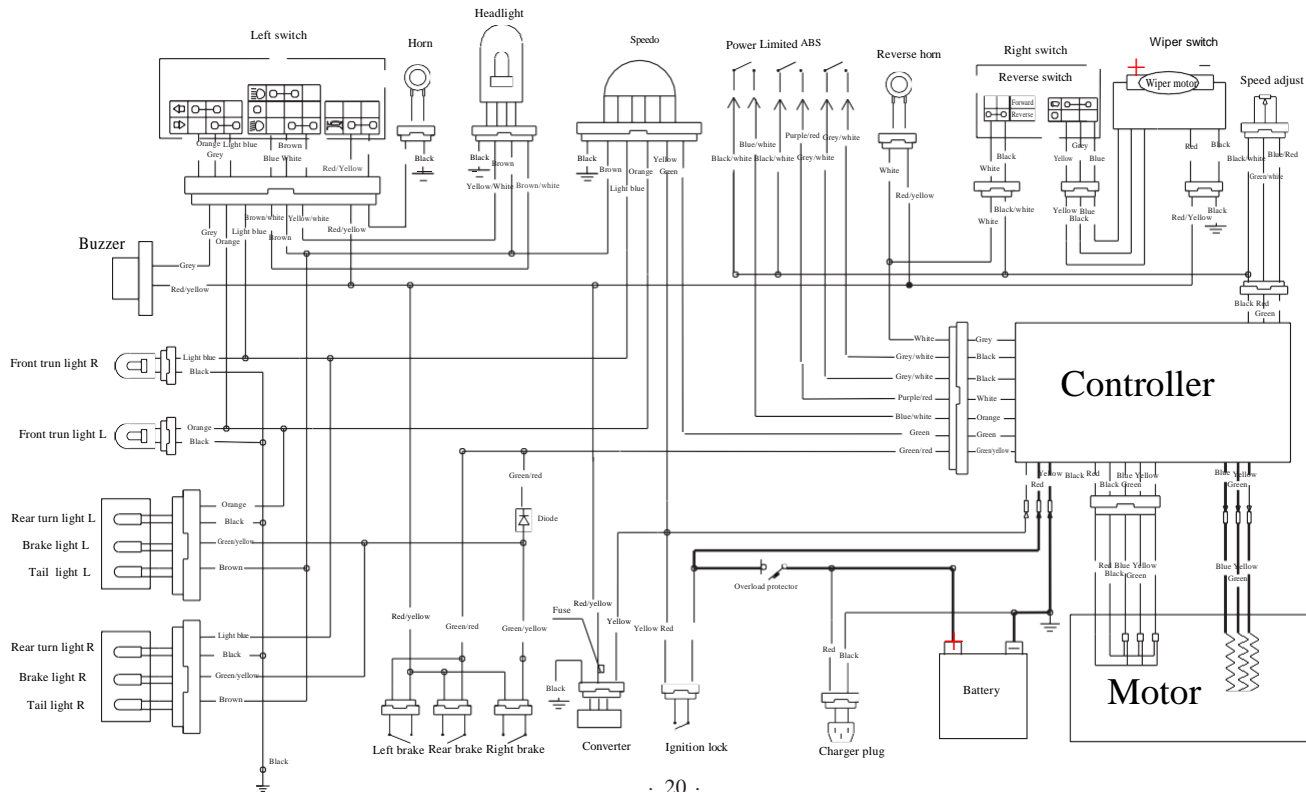

version one 2016